

TOSHIBA MACHINE

NEW PRODUCT

VERTICAL ARTICULATED ROBOT

TV800

EZCell

PROGRAMMING SUPPORT TOOL
EASY OPERATION!
EASY PROGRAMMING!
EASY CONVERSION FROM CAD/CAM DATA!

RETURN OF INVESTMENT

HIGH RIGIDITY
HIGH DURABILITY
FAST CYCLE TIME
LIGHT WEIGHT DESIGN
USER FRIENDLY SOFTWARE

Robot Specifications



Option	Dustproof and splashproof specifications	Equivalent to IP65
	Clean type specifications	ISO class 3:0.1 μ m ^{*4}

*4: In a cleanroom environment with a downflow of 0.4m/s or higher. Used with the packing option and a cleaning air rate of 30NI/min or higher. These specifications do not apply to the controller. Provide cleaning air from one 6mm diameter tube line in the base unit for supplying air to the inside of arm 2.

Controller Specifications



Controller
TS3100

TEACH PENDANT(OPTION)

Model	TV800	
Type	Vertical Articulated Robot	
Number of controlled axis	6 axis	
Arm Length	Total Length	800mm
	1st Arm	380mm
	2nd Arm	420mm
Reach	892mm	
Working envelope	Axis 1(J1)	$\pm 170^\circ$
	Axis 2(J2)	$-100 \sim +150^\circ$
	Axis 3(J3)	$-127 \sim +167^\circ$
	Axis 4(J4)	$\pm 190^\circ$
	Axis 5(J5)	$\pm 120^\circ$
	Axis 6(J6)	$\pm 360^\circ$
Maximum speed*1	Axis 1(J1)	237°/s
	Axis 2(J2)	240°/s
	Axis 3(J3)	288°/s
	Axis 4(J4)	350.5°/s
	Axis 5(J5)	484°/s
	Axis 6(J6)	576°/s
Composite	8.06m/sec	
Maximum payload mass	5kg	
Standard cycle time*2	0.4~0.5sec	
Allowable moment of inertia at end	Axis 4,5	0.3kg·m ²
	Axis 6	0.05kg·m ²
Positioning repeatability*3	± 0.02 mm(X-Y-Z)	
Position detecting system	Absolute system/AC servo motor	
Robot body	Mass	45kg
	Color	Light gray/White

*1: The acceleration/deceleration rates may be limited depending on motion patterns, load mass and offset amount.

*2: Continuous operation is not possible beyond the effective load ratio on the standard cycle time motion pattern.

Horizontal 300mm, Vertical 25mm, round-trip

*3: At constant temperature

Model	TS3100	
No. of axis	Maximum eight-axis simultaneous control	
Operation mode	PTP, CP(linear·Circular), Short-cut, Arch motion	
Storage capacity	Total: 12800 points + 25600 steps	
	1 program: 2000 points + 3000 steps	
No. of programs	Max.256(247 user files + 9 system files)	
Programming language	SCOL(proprietary, similar to BASIC)	
Teaching unit(option)	Teach pendant TP1000, with 5-meter cable (Program can be written on PC)	
External I/O	32 inputs/32 outputs	
Hand control signals	8 inputs/8 outputs	
External operation signal(exclusive)	Inputs: Cycle operation start, stop, reset, etc Outputs: Servo-On status, emergency stop, ready for operation, malfunction alarm, etc	
Serial communication port	RS-232C: 2 ports, Ethernet: 1 port*5	
Other functions	Torque control, Interruptive functions, self-diagnosis, I/O control and communications during motion, Coordinate calculations, Built-in PLC, etc	
Power supply	Single phase AC200V~240V 50/60Hz 4.4kVA	
Outer dimensions and mass	420W×230H×298D(mm), 17kg	
PC software(option)	TSPC...Program editor, Teaching, Remote operation, etc	
Options	I/O extension, I/O cables, Field-Network(CC-Link, DeviceNet, Profibus)*5	

*5: Ethernet is a registered trademark of XEROX Corp. in the U.S.A.

CC-Link is a registered trademark of CC-Link Partner Association.

DeviceNet is a registered trademark of ODVA.

Profibus is a registered trademark of Profibus User Organization.

TV800 [External View]

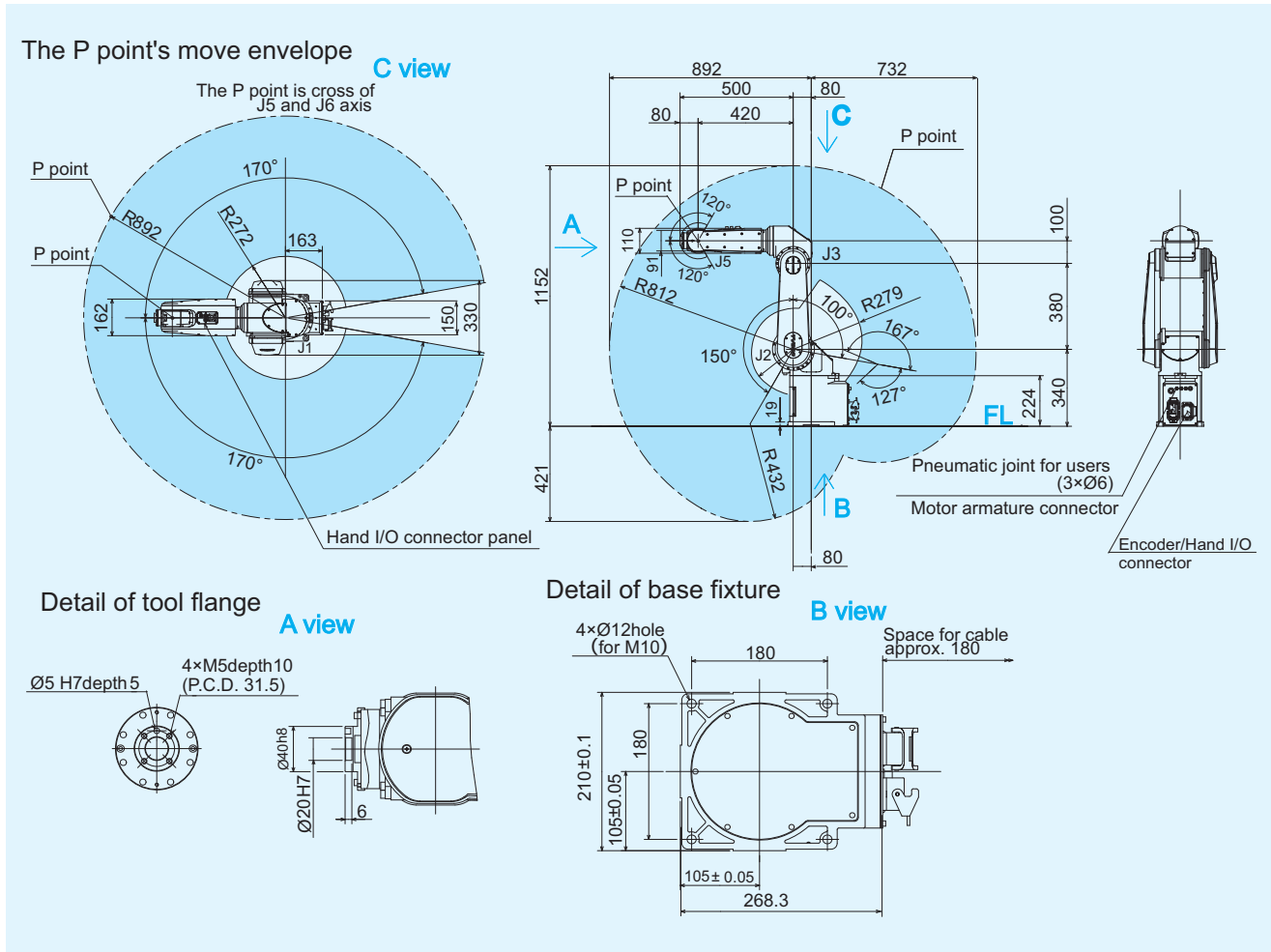

TS3100 [External View]

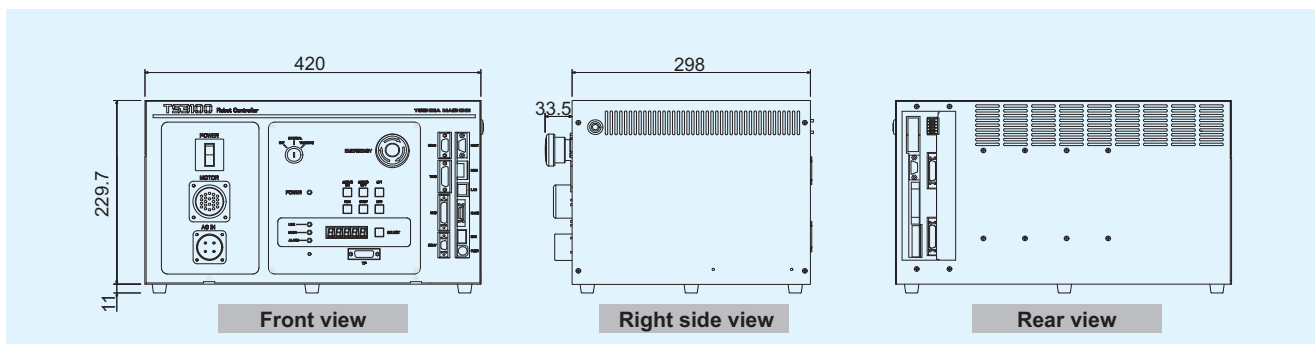

TOSHIBA MACHINE CO.,LTD.
 Control Systems Sales Department, Control Systems Division
 2-2, Uchisaiwaicho 2-Chome, Chiyoda-ku, Tokyo 100-8503, Japan
 TEL:[81]-(0)3-3509-0362 FAX:[81]-(0)3-3509-0335

TOSHIBA MACHINE CO.,AMERICA.
 755 Greenleaf Avenue, EIK Grove Village, IL 60007, U.S.A.
 TEL:[1]-847-593-1616 FAX:[1]-847-593-0897

TM ROBOTICS(EUROPE) LTD.
 Unit 2, Bridge Gate Centre, Martinfield,
 Welwyn Garden City, Herts AL7 1JG, UK
 TEL:[44]-(0)1707-290370 FAX:[44]-(0)1707-376662

URL:<http://www.toshiba-machine.co.jp/seiji/prod/sr>
http://www.toshiba-machine.com/robotics/SR_homepagef.htm
<http://www.tmrobotics.co.uk>